

Unità motocondensante - Condensing unit
Verdichter-Verflüssiger-Einheit - Groupe de condensation

NGA

Dimensioni - Dimensions - Maße - Dimensions	mm	2.920x1.040x1.625H
Peso - Weight - Gewicht - Poids	kg	950
Ø OUT/IN evap. - Ø OUT/IN evap. - Ø AUS/EIN Verd. - Ø OUT/IN evap.	mm	54/22
Ø IN/OUT cond. - Ø IN/OUT cond. - Ø EIN/AUS Verfl. - Ø IN/OUT cond.	mm	42/22
Ricevitore di liquido - Liquid receiver - Kältemittelsammler - Bouteille de liquide	l	50
Numero compressori - Compressor number - Anzahl Verdichter - Nombre compresseurs	#	3
Circuiti frigoriferi - Refrigerant circuits - Kältekreise - Circuits frigorifiques	#	1
Potenza motore - Motor power - Motorleistung - Puissance moteur	HP	10,0
Costruttore - Manufacturer - Hersteller - Fabricant		Bitzer
Modello - Model - Typ - Modèl		4P-10.2Y

Resa frigorifera totale in kW - Total cooling capacity rating in kW
Gesamtkälteleistung des in kW - Puissance frigorifique totale en kW

t _c	t _e				Condizioni operative – Operating conditions*
	-20	-25	-30	-35	
+30	61,80	48,99	38,07	28,80	25 °C temperatura gas aspirato; 0 K sottoraffreddamento
+40	52,77	41,43	31,77	23,58	25 °C suction gas return; 0 K liquid subcooling
+50	43,23	33,54	25,29	18,27	25 °C sauggas temperatur; 0 K flüssigkeitsunterkühlung
					25 °C gaz aspirés; 0 K sous-refroid. de liquide

Dati elettrici globali - Global electric datas - Elektrische Gesamtwerte - Données électriques globales

Alimentazione - Power supply - Anschluß - Alimentation	V/~ / Hz	400 / 3+N / 50
Potenza max. ass. - Max. abs. power - Max. Leistungsaufn. - Puissance max.abs.	kW	22,08
Corrente max. ass. - Max. abs. current - Max. Stromaufn. - Courant max.abs.	A	63,0

* Resa frigorifera come dichiarato dai costruttori dei compr. secondo ISO 9309/8928 - Cooling capacity as indicated by the compress. manufactures according to ISO 9309/8928 Kälteleistung gemäß Herstellerangaben nach ISO 9309/8928 - Puissance frigorifique coome indiqué par les constructeurs des compresseurs selon ISO 9309/8928

LT CP ST

-36/ +42 °C subcooling 3°C; superheating 10°C

Modello Model Modell Modele	Compressore Compressor Compresseur Verdichter	Q -36/+42°C R404A [kW]	P max 400V - 3+N - 50Hz [kW]	I max [A]	Data dimensionali - Dimensional datae Dimensional daten - Dimensional données				Connessioni frigorifere - Refrigerant connections Kälteleitungsanschlüsse - Connexions frigorifique				
					Structure	A [mm]	B [mm]	H [mm]	Weight [kg]	To condenser [mm]	From cond. [mm]	To users [mm]	From users [mm]
LT CP 2X8 ST	4T-8.2Y	10,00	11,04	34,0	NGA	1.980	1.040	1.625	634	35	16	16	42
LT CP 2X10 ST	4P-10.2Y	11,54	14,72	42,0	NGA	1.980	1.040	1.625	678	35	22	22	42
LT CP 2X13 ST	4J-13.2Y	16,34	19,14	54,0	NGA	1.980	1.040	1.625	780	35	22	22	54
LT CP 2X15 ST	4H-15.2Y	19,26	22,08	62,0	NGA	1.980	1.040	1.625	805	42	22	22	2x42
LT CP 2X20 ST	4G-20.2Y	22,42	29,44	74,0	NGA	2.920	1.040	1.625	900	42	28	28	2x54
LT CP 2X25 ST	6H-25.2Y	28,90	36,80	90,0	NGA	2.920	1.040	1.625	1.010	54	28	28	2x54
LT CP 2X30 ST	6G-30.2Y	33,64	44,16	106,0	NGA	2.920	1.040	1.625	1.118	54	35	35	2x54
LT CP 2X40 ST	6F-40.2Y	39,66	58,88	156,0	NGA	2.920	1.040	1.625	1.395	54	35	35	2x54
LT CP 3X8 ST	4T-8.2Y	15,00	16,56	51,0	NGA	2.920	1.040	1.625	880	42	22	22	54
LT CP 3X10 ST	4P-10.2Y	17,31	22,08	63,0	NGA	2.920	1.040	1.625	950	42	22	22	54
LT CP 3X13 ST	4J-13.2Y	24,51	28,70	81,0	NGA	2.920	1.040	1.625	980	42	22	22	2x42
LT CP 3X15 ST	4H-15.2Y	28,89	33,12	93,0	NGA	2.920	1.040	1.625	1.050	42	28	28	2x42
LT CP 3X20 ST	4G-20.2Y	33,63	44,16	111,0	NGA	2.920	1.040	1.625	1.183	54	28	28	64
LT CP 3X25 ST	6H-25.2Y	43,35	55,20	135,0	NGA	2.920	1.500	1.625	1.354	54	28	28	2x54
LT CP 3X30 ST	6G-30.2Y	50,46	66,24	159,0	NGA	2.920	1.500	1.625	1.490	54	35	35	2x64
LT CP 3X40 ST	6F-40.2Y	59,49	88,32	234,0	NGA	2.920	1.500	1.625	1.650	64	35	35	2x64

Equilibratura olio con sistema AC&R - Compressor oil level regulation with AC&R system

Verdichterölniveauregulierung mit AC&R System - Régulation du niveau l'huile des compresseur avec système AC&R

Per il dimensionamento e la fornitura di condensatore ad acqua od aria remoto contattare il Ns. ufficio tecnico commerciale

For the dimensioning and the supply of the water condenser or the remote air condenser, please contact our technical-commercial office

Für die Auslegung und Lieferung wasser- oder luftgekühlter Verflüssiger setzen Sie sich mit unser technisch-kaufmännisches Büro in Verbindung

Pour la sélection et la fourniture de condenseurs à eau ou à air rémotes, contacter notre bureau technique-commercial

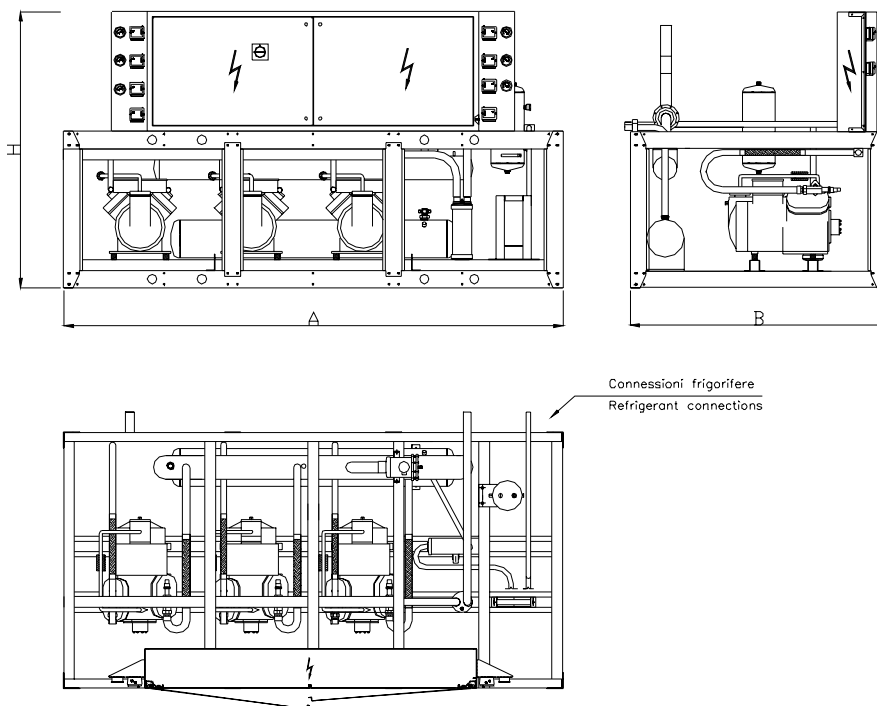

Struttura - Structure - Gehäuse - Structure " NGA "

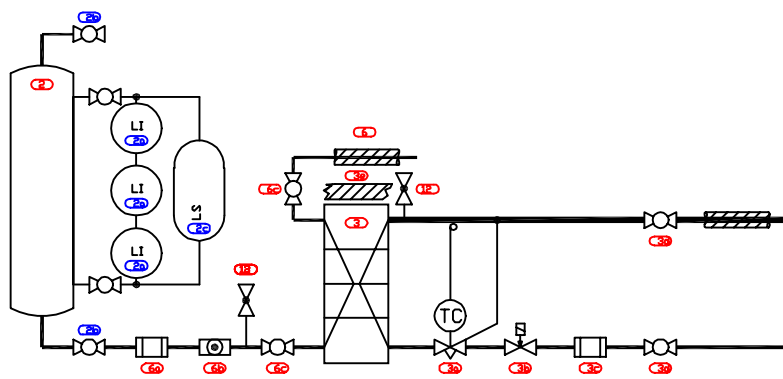
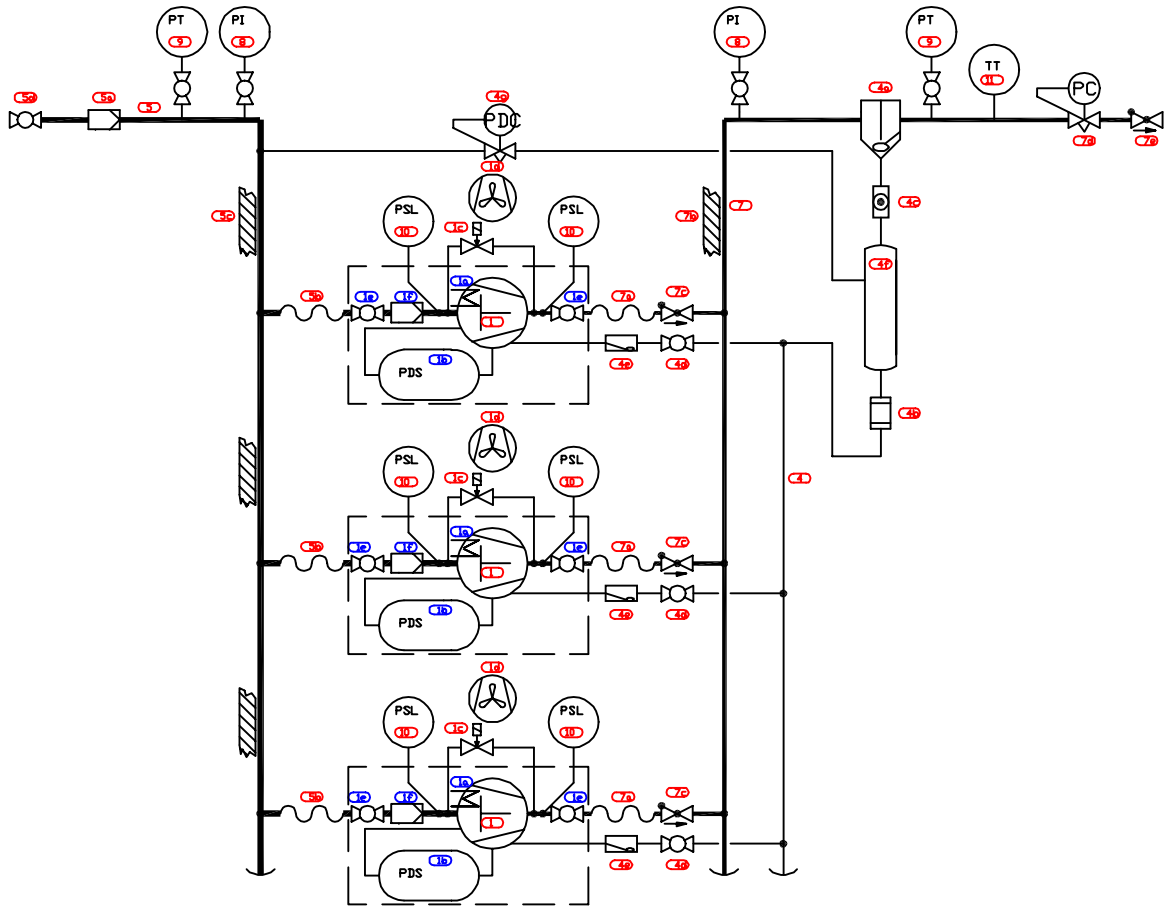

3 compressor Compressor Pack (LT)
with oil levelling system
and subcooling

No.	Symbol	Description
1.		semihermetic compressor with equipment
2.		semihermetic compressor
3.		crankcase heater
4.		rotalock valve
5.		internal suction filter
6.		pressure differential switch
7.		solenoid valve (NC)
8.		antivibrating pipe
9.		head cooling fan
10.		check valve
11.		shut-off valve
12.		suction filter
13.		insulation
13.		oil separator
15.		oil receiver
16.		pressure regulator
17.		pressure differential regulator
18.		sightglass
19.		oil filter
20.		oil level regulator

Standard_compressorpacks-leg.dwg

21.		liquid receiver
22.		thermostatic exp. valve with external pressure equalization
23.		liquid subcooler
24.		filter-drier
25.		level switch
26.		liquid indicator (sight glass)
27.		service valve
28.		temperature sensor
29.		pressure sensor
30.		pressure indicator
31.		pressure switch low
32.		pressure switch high
33.		suction line
34.		discharge line
35.		liquid line
36.		oil line
37.		item no.
38.		subitem no.
39.		limits item with subitems

Standard_compressorpacks-leg.dwg