

Unità motocondensante - Condensing unit
Verdichter-Verflüssiger-Einheit - Groupe de condensation

NGA

Dimensioni - Dimensions - Maße - Dimensions	mm	2.920x1.500x1.625H
Peso - Weight - Gewicht - Poid	kg	1.395
Ø OUT/IN evap. - Ø OUT/IN evap. - Ø AUS/EIN Verd. - Ø OUT/IN evap.	mm	2x64 /42
Ø IN/OUT cond. - Ø IN/OUT cond. - Ø EIN/AUS Verfl. - Ø IN/OUT cond.	mm	76/42
Ricevitore di liquido - Liquid receiver - Kältemittelsammler - Bouteille de liquide	l	150
Numero compressori - Compressor number - Anzahl Verdichter - Nombre compresseurs	#	2
Circuiti frigoriferi - Refrigerant circuits - Kältekreise - Circuits frigorifiques	#	1
Potenza motore - Motor power - Motorleistung - Puissance moteur	HP	70,0
Costruttore - Manufacturer - Hersteller - Fabricant		Bitzer
Modello - Model - Typ - Modèl		HSN 7461-70

Resa frigorifera totale in kW - Total cooling capacity rating in kW
Gesamtkälteleistung des in kW - Puissance frigorifique totale en kW

t _c	t _e				Condizioni operative – Operating conditions*
	-30	-35	-40	-45	
+30	164,60	134,00	106,80	82,60	20 K surriscald. gas aspirato; con economizzatore
+40	148,80	119,60	93,40	69,60	20 K suction gas superheat; with economizer
+50	130,00	102,60	77,40	-	20 K sauggasüberhitzung; mit ekonomiser
					20 K surchauffe à l'aspiration; avec économiseur

Dati elettrici globali - Global electric datas - Elektrische Gesamtwerte - Données électriques globales

Alimentazione - Power supply - Anschluß - Alimentation	V~/Hz	400 / 3+N / 50
Potenza max. ass. - Max. abs. power - Max. Leistungsaufn. - Puissance max.abs.	kW	103,04
Corrente max. ass. - Max. abs. current - Max. Stromaufn. - Courant max.abs.	A	248,0

* Resa frigorifera come dichiarato dai costruttori dei compr. secondo ISO 9309/8928 - Cooling capacity as indicated by the compress. manufactures according to ISO 9309/8928 Kälteleistung gemäß Herstellerangaben nach ISO 9309/8928 - Puissance frigorifique coome indiqué par les constructeurs des compresseurs selon ISO 9309/8928

LT CP ST V

-36/ +42 °C superheating 10°C

Modello Model Modell Modelle	Compressore Compressor Compresseur Verdichter	Q -36/+42°C [kW]	P max 400V - 3+N - 50Hz [kW]	I max [A]	Dati dimensionali - Dimensional datae Dimensional daten - Dimensional données				Connessioni frigorifere - Refrigerant connections Kälteleitungsanschlüsse - Connexions frigorifique				
					Structure	A [mm]	B [mm]	H [mm]	Weight [kg]	To condenser [mm]	From cond. [mm]	To users [mm]	From users [mm]
LT CP 2X50 ST V	HSN6461-50	81,80	73,60	158,0	NGA	2.920	1.500	1.625	1.110	64	35	35	76
LT CP 2X60 ST V	HSN7451-60	91,40	88,32	196,0	NGA	2.920	1.500	1.625	1.190	76	42	42	2x64
LT CP 2X70 ST V	HSN7461-70	109,20	103,04	248,0	NGA	2.920	1.500	1.625	1.395	76	42	42	2x64
LT CP 2X75 ST V	HSN7471-75	124,00	110,40	288,0	NGA	2.920	1.500	1.625	1.455	76	42	42	2x76
LT CP 3X50 ST V	HSN6461-50	122,70	110,40	237,0	NGA	3.960	1.500	1.625	1.655	64	42	42	2x64
LT CP 3X60 ST V	HSN7451-60	137,10	132,48	294,0	NGA	3.960	1.500	1.625	1.770	76	42	42	2x76
LT CP 3X70 ST V	HSN7461-70	163,80	154,56	372,0	NGA	3.960	1.500	1.625	2.095	76	54	54	3x76
LT CP 3X75 ST V	HSN7471-75	186,00	165,60	432,0	NGA	3.960	1.500	1.625	2.190	76	54	54	3x76
LT CP 4X50 ST V	HSN6461-50	163,60	147,20	316,0	NGA	4.500	1.700	2.000	2.350	76	42	42	3x76
LT CP 4X60 ST V	HSN7451-60	182,80	176,64	392,0	NGA	4.500	1.700	2.000	2.530	76	54	54	3x76
LT CP 4X70 ST V	HSN7461-70	218,40	206,08	496,0	NGA	4.500	1.700	2.000	2.760	89	64	64	4x76
LT CP 4X75 ST V	HSN7471-75	248,00	220,80	576,0	NGA	4.500	1.700	2.000	2.890	89	64	64	4x76

Per il dimensionamento e la fornitura di condensatore e raffreddatore olio ad acqua od aria remota, contattare nostro ufficio tecnico commerciale

For the layout and the supply of the water or air cooled condensers and oilcoolers, please contact our technical-commercial department

Für die Auslegung und die Lieferung von wasser- oder luftgekühlten Verflüssiger bzw. Ölkühler, wenden Sie sich bitte an unser technisch-kaufmännisches Büro

Pour la sélection et la livraison de condenseurs et refroidisseurs d'huile à air ou bien à eau, contacter s.v.p. notre bureau technico-commerciale

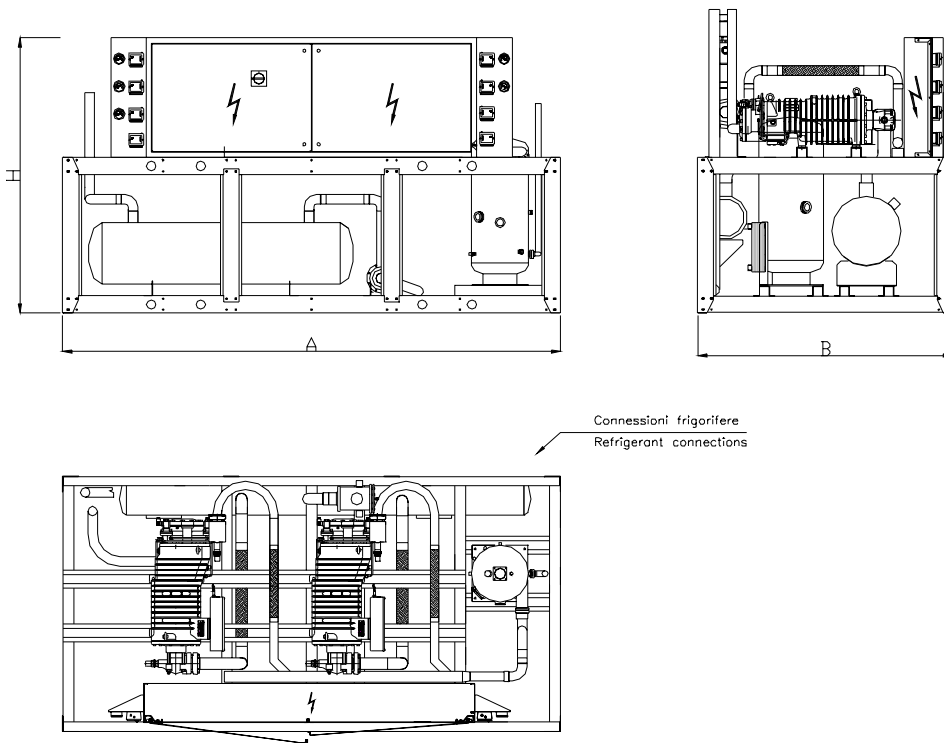

Struttura - Structure - Gehäuse - Structure " NGA "

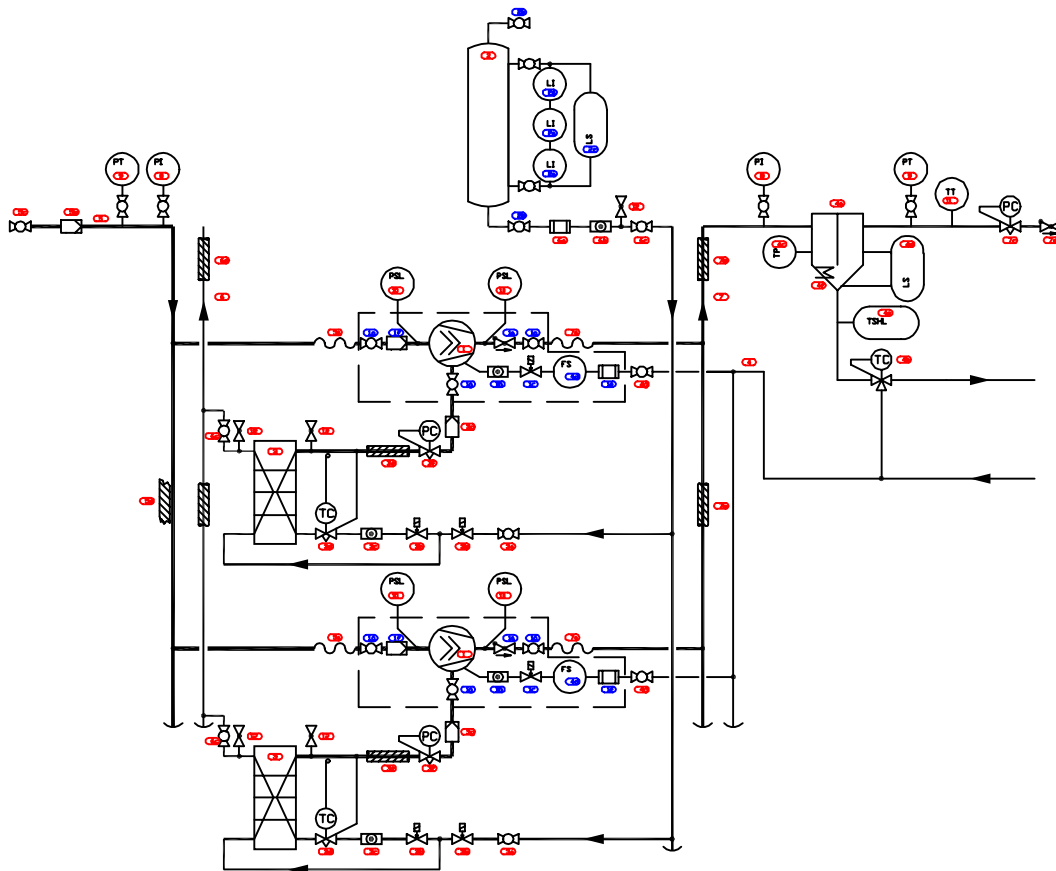

2 screw compressor Compressor Pack (LT)
with economiser

No.	Symbol	Description
1.		semihermetic compressor with equipment
2.		semihermetic compressor
3.		crankcase heater
4.		rotalock valve
5.		internal suction filter
6.		pressure differential switch
7.		solenoid valve (NC)
8.		antivibrating pipe
9.		head cooling fan
10.		check valve
11.		shut-off valve
12.		suction filter
13.		insulation
13.		oil separator
15.		oil receiver
16.		pressure regulator
17.		pressure differential regulator
18.		sightglass
19.		oil filter
20.		oil level regulator

Standard_compressorpacks-leg.dwg

21.		liquid receiver
22.		thermostatic exp. valve with external pressure equalization
23.		liquid subcooler
24.		filter-drier
25.		level switch
26.		liquid indicator (sight glass)
27.		service valve
28.		temperature sensor
29.		pressure sensor
30.		pressure indicator
31.		pressure switch low
32.		pressure switch high
33.		suction line
34.		discharge line
35.		liquid line
36.		oil line
37.		item no.
38.		subitem no.
39.		limits item with subitems

Standard_compressorpacks-leg.dwg