

Unità motocondensante - Condensing unit
Verdichter-Verflüssiger-Einheit - Groupe de condensation

NGA

Dimensioni - Dimensions - Maße - Dimensions	mm	3.960x1.500x1.625H
Peso - Weight - Gewicht - Poids	kg	1.720
Ø OUT/IN evap. - Ø OUT/IN evap. - Ø AUS/EIN Verd. - Ø OUT/IN evap.	mm	2x64/54
Ø IN/OUT cond. - Ø IN/OUT cond. - Ø EIN/AUS Verfl. - Ø IN/OUT cond.	mm	76/54
Ricevitore di liquido - Liquid receiver - Kältemittelsammler - Bouteille de liquide	l	200
Numero compressori - Compressor number - Anzahl Verdichter - Nombre compresseurs	#	3
Circuiti frigoriferi - Refrigerant circuits - Kältekreise - Circuits frigorifiques	#	1
Potenza motore - Motor power - Motorleistung - Puissance moteur	HP	60,0
Costruttore - Manufacturer - Hersteller - Fabricant		Bitzer
Modello - Model - Typ - Modèl		HSK 6461-60

Resa frigorifera totale in kW - Total cooling capacity rating in kW
Gesamtkälteleistung des in kW - Puissance frigorifique totale en kW

t _c	t _e				Condizioni operative – Operating conditions*
	0	-5	-10	-15	
+30	498,00	414,60	342,00	279,60	20 K surriscald. gas aspirato; 5 K sottoraffreddamento
+40	428,40	354,30	290,10	234,60	20 K suction gas superheat; 5 K liquid subcooling
+50	351,60	288,00	232,20	183,00	20 K sauggasüberhitzung; 5 K flüssigkeitsunterkühlung
					20 K surchauffe à l'aspiration; 5 K sous-refroid. de liquide

Dati elettrici globali - Global electric datas - Elektrische Gesamtwerte - Données électriques globales

Alimentazione - Power supply - Anschluß - Alimentation	V/~ / Hz	400 / 3+N / 50
Potenza max. ass. - Max. abs. power - Max. Leistungsaufn. - Puissance max.abs.	kW	132,48
Corrente max. ass. - Max. abs. current - Max. Stromaufn. - Courant max.abs.	A	294,0

* Resa frigorifera come dichiarato dai costruttori dei compr. secondo ISO 9309/8928 - Cooling capacity as indicated by the compress. manufactures according to ISO 9309/8928 Kälteleistung gemäß Herstellerangaben nach ISO 9309/8928 - Puissance frigorifique coome indiqué par les constructeurs des compresseurs selon ISO 9309/8928

MT CP ST V

-10/ +42 °C subcooling 3°C; superheating 10°C

Modello Model Modell Modelle	Compressore Compressor Compresseur Verdichter	Q -10/+42°C R404A [kW]	P max 400V - 3+N - 50Hz [kW]	I max [A]	Detli dimenzionall - Dimensional datae Dimensional daten - Dimensional données				Connessioni frigorifere - Refrigerant connections Kälteleitungsanschlüsse - Connexions frigorifique				
					Structure	A [mm]	B [mm]	H [mm]	Weight [kg]	To condenser [mm]	From cond. [mm]	To users [mm]	From users [mm]
MT CP 2X50 ST V	HSK6451-50	147,60	73,60	158,0	NGA	2.920	1.500	1.625	1.080	64	35	35	76
MT CP 2X60 ST V	HSK6461-60	173,80	88,32	196,0	NGA	2.920	1.500	1.625	1.145	64	42	42	2x54
MT CP 2X70 ST V	HSK7451-70	202,40	103,04	248,0	NGA	2.920	1.500	1.625	1.360	76	42	42	2x64
MT CP 2X80 ST V	HSK7461-80	231,80	117,76	288,0	NGA	2.920	1.500	1.625	1.420	2x54	42	42	2x64
MT CP 2X90 ST V	HSK7471-90	263,40	132,48	324,0	NGA	2.920	1.500	1.625	1.590	2x54	54	54	2x76
MT CP 3X50 ST V	HSK6451-50	221,40	110,40	237,0	NGA	3.960	1.500	1.625	1.605	64	42	42	2x64
MT CP 3X60 ST V	HSK6461-60	260,70	132,48	294,0	NGA	3.960	1.500	1.625	1.720	76	54	54	2x64
MT CP 3X70 ST V	HSK7451-70	303,60	154,56	372,0	NGA	3.960	1.500	1.625	1.980	2x64	54	54	2x76
MT CP 3X80 ST V	HSK7461-80	347,70	176,64	432,0	NGA	3.960	1.500	1.625	2.080	2x64	64	64	3x76
MT CP 3X90 ST V	HSK7471-90	395,10	198,72	486,0	NGA	3.960	1.500	1.625	2.360	2x76	76	76	3x76

Per il dimensionamento e la fornitura di condensatore e raffreddatore olio ad acqua od aria remoto, contattare nostro ufficio tecnico commerciale

For the layout and the supply of the water or air cooled condensers and oilcoolers, please contact our technical-commercial department

Für die Auslegung und die Lieferung von wasser- oder luftgekühlten Verflüssiger bzw. Ölkühler, wenden Sie sich bitte an unser technisch-kaufmännisches Büro

Pour la sélection et la livraison de condenseurs et refroidisseurs d'huile à air ou bien à eau, contacter s.v.p. notre bureau technico-commercial

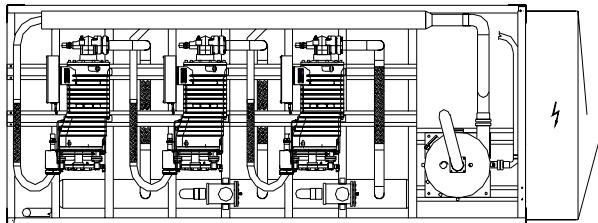
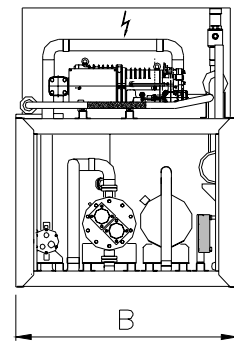
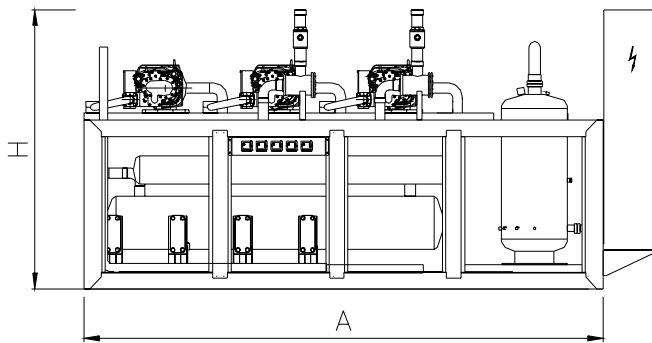

Struttura - Structure - Gehäuse - Structure " NGA "

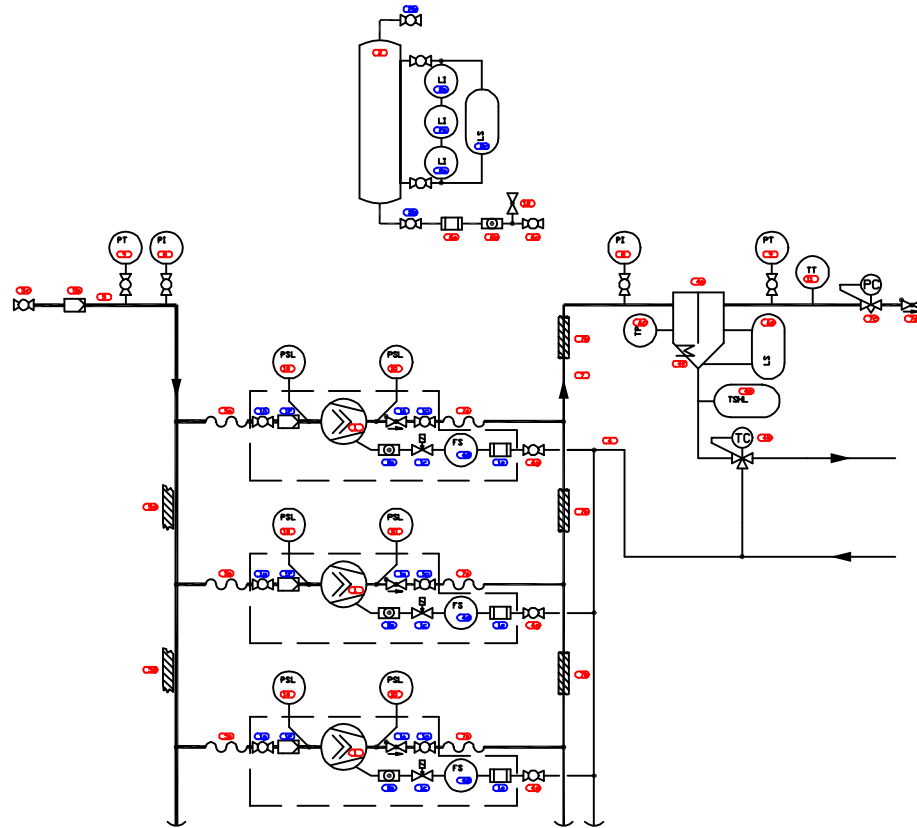

3 screw compressor Compressor Pack (HT)
without economiser

No.	Symbol	Description
1.		semihermetic compressor with equipment
2.		semihermetic compressor
3.		crankcase heater
4.		rotalock valve
5.		internal suction filter
6.		pressure differential switch
7.		solenoid valve (NC)
8.		antivibrating pipe
9.		head cooling fan
10.		check valve
11.		shut-off valve
12.		suction filter
13.		insulation
13.		oil separator
15.		oil receiver
16.		pressure regulator
17.		pressure differential regulator
18.		sightglass
19.		oil filter
20.		oil level regulator

Standard_compressorpacks-leg.dwg

21.		liquid receiver
22.		thermostatic exp. valve with external pressure equalization
23.		liquid subcooler
24.		filter-drier
25.		level switch
26.		liquid indicator (sight glass)
27.		service valve
28.		temperature sensor
29.		pressure sensor
30.		pressure indicator
31.		pressure switch low
32.		pressure switch high
33.		suction line
34.		discharge line
35.		liquid line
36.		oil line
37.		item no.
38.		subitem no.
39.		limits item with subitems

Standard_compressorpacks-leg.dwg